

DC Centrifugal Fan BGN Series

SIZE/尺寸 : Ø175X69mm

General Specifications (一般規格)

Motor : DC Brushless motor	馬達 : 直流單向無刷馬達
Frame : die cast aluminum	材料 : 框 : 鋁合金壓鑄
Impeller : Plastic PA66	材料 : 葉 : 塑膠PA66
Bearing : Ball bearing	軸承 : 滾珠軸承
Weight : 770g	重量 : 770克



Major Characteristic Parameters 主要參數

Model 機型	Bearing 軸承	Voltage 電壓	Current 電流	Speed 轉速	Max Air Flow 最大風量	Max Static Pressure 最大風壓	Sound 噪音
Part NO.	B / F / S	V	A	RPM	m3/min CFM	mm-H ₂ O In-H ₂ O	dBA
BGN17569B12H	B	12	3.50	3000	8.7 308.0	33.17 1.31	62
BGN17569B24H	B	24	1.90	3300	9.6 339.4	39.56 1.56	64
BGN17569B24U	B	24	3.00	3800	11.3 399.0	49.04 1.93	71
BGN17569B48H	B	48	1.00	3300	9.6 339.4	39.56 1.56	64
BGN17569B48U	B	48	2.00	4200	12.2 431.2	60.26 2.37	73

Drawing & panel out-cuts 圖面及出入風口

Characteristic Curves 特性曲線

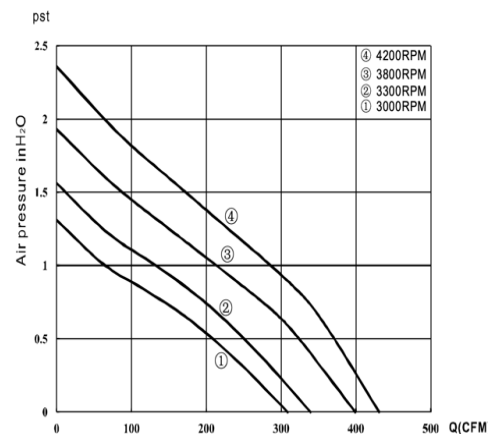
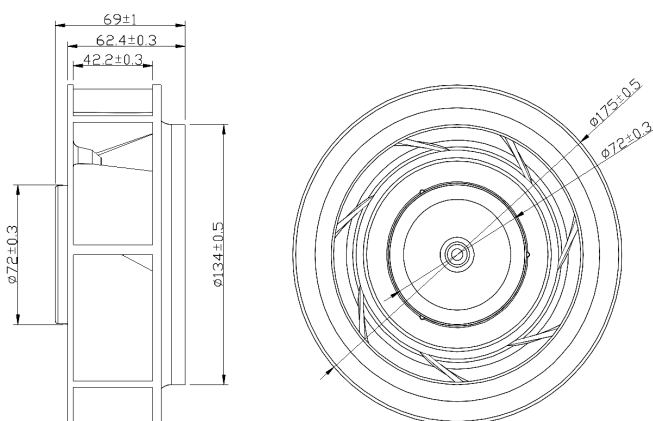

Specification is subject to change for improvement without notice/ 基於改良的規格變更, 不另行通知

<http://www.crownelectronics.ltd>

